



さし込み溶接形ユニオン  
SOCKET-WELDING UNIONS

SWU  
(UNIONS)

(O RING TYPE)

ステンレス用  
FOR STAINLESS STEEL

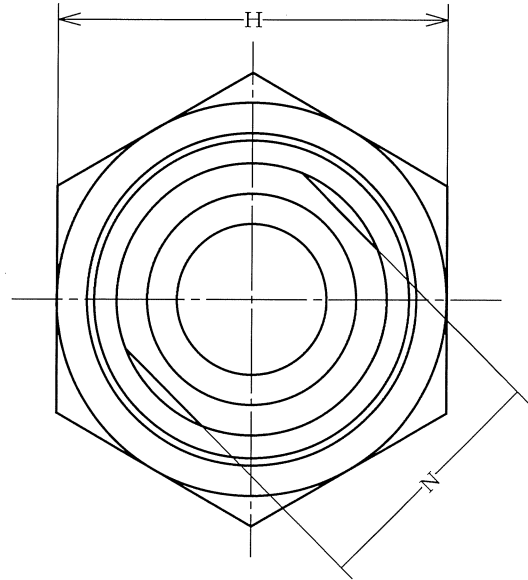
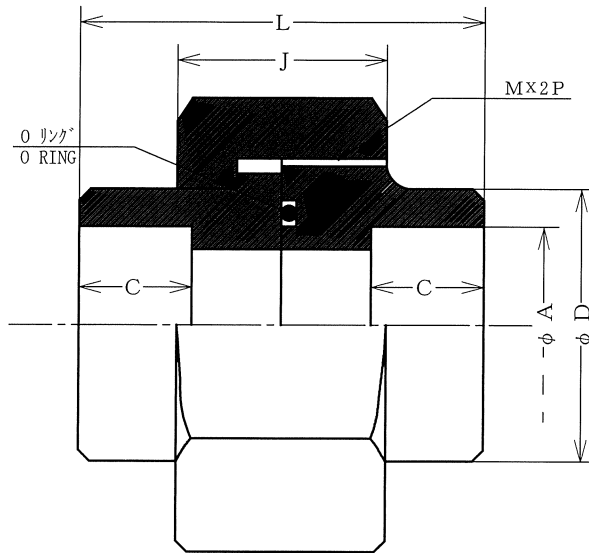

S W U

UNIT : mm

NOM. SIZE		A	D	L	C	J	M	H	O RING
(A)	(B)								
8	1/4	14.3	22.0	38.0	11.0	18.0	28.0	32.0	P18
10	3/8	17.8	26.0	40.0	12.0	20.0	36.0	41.0	P20
15	1/2	22.2	32.0	44.0	13.0	22.0	39.0	46.0	G25
20	3/4	27.7	38.0	50.0	16.0	26.0	45.0	54.0	G30
25	1	34.5	47.0	56.0	17.0	28.0	55.0	63.0	G35
32	1-1/4	43.2	58.0	62.0	18.0	30.0	65.0	<sup>OCT</sup> 74.0	G45
40	1-1/2	49.1	63.0	70.0	20.0	32.0	72.0	<sup>OCT</sup> 80.0	G50
50	2	61.1	76.0	76.0	23.0	36.0	85.0	<sup>OCT</sup> 95.0	G65

特記 : 1. スリ合せ又はガスケットタイプは御用命に依り製作致します。

2. Oリングは JIS B2401

REMARKS : 1. GROUND OR GASKET TYPE SHALL BE MADE TO ORDER.

2. O RING IS JIS B2401

ヤマト特殊鋼株式会社  
YAMATO SPECIAL STEEL CO., LTD.

Sheet No. JSW-9

平成22年1月5更新