

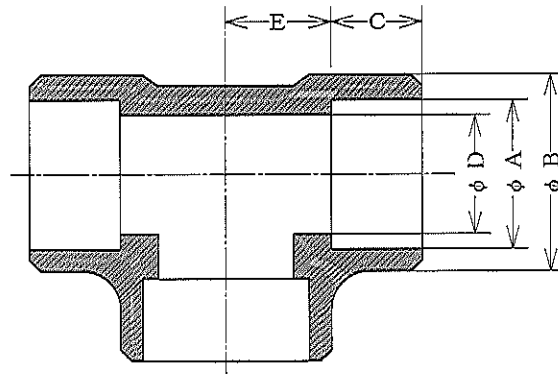

さし込み溶接形ティー
SOCKET-WELDING TEES

SWT (TEES)

JIS B2316



S W T

UNIT : mm

NOM. SIZE		Sch 80				
(A)	(B)	B	A	D	C	E
8	1/4	23.0	14.3	9.4	10.5	11.1
10	3/8	27.0	17.8	12.7	12.0	13.5
15	1/2	34.0	22.2	16.1	13.0	15.9
20	3/4	39.0	27.7	21.4	14.0	19.1
25	1	47.0	34.5	27.2	16.0	22.2
32	1-1/4	56.0	43.2	35.5	18.0	27.0
40	1-1/2	63.0	49.1	41.2	19.0	31.8
50	2	76.0	61.1	52.7	22.0	38.1
65	2-1/2	96.0	77.1	65.9	26.0	41.3
80	3	109.6	90.0	78.1	29.0	57.2
NOM. SIZE		Sch 160				
(A)	(B)	B	A	D	C	E
15	1/2	39.0	22.2	12.3	14.0	19.1
20	3/4	47.0	27.7	16.2	16.0	22.2
25	1	56.0	34.5	21.2	18.0	27.0
32	1-1/4	63.0	43.2	29.9	19.0	31.8
40	1-1/2	76.0	49.1	34.4	22.0	38.1

特註：異径チーザーC, Eは大径側に等しく、
原則としてDは各々のサイズに対応する。

REMARK: RED. TEE-C, E IS EQUAL TO LARGER SIZE
AND D, IS CORRESPONDING TO EACH IN PRINCIPLE.

ヤマト特殊鋼株式会社
YAMATO SPECIAL STEEL CO., LTD.

Sheet No. JW-2

平成22年1月5更新